

# ELECTRONIC BALLAST V3

## 800W/575W

(Multi-Voltage)



### 800W/575W V3 (Multi-Voltage)

SPECIFICATIONS	(1000Hz)	(300Hz)
Identity No.	B008PEK3 (1000Hz, DMX) B008PNK3 (1000Hz)	B008PEX3 (300Hz, DMX) B008PNX3 (300Hz)
Max. Power	880VA	880VA
Input Voltage	90 - 125V AC 180 - 250V AC	90 - 125V AC 180 - 250V AC
Input Current	5 - 4A @ 180 - 250V AC 10 - 7A @ 90 - 125V AC	5 - 4A @ 180 - 250V AC 10 - 7A @ 90 - 125V AC
Frequency	50Hz or 60Hz	50Hz or 60Hz
Output Mode	60Hz (Silent) 75Hz (Flicker Free) 1000Hz (High Speed)	60Hz (Silent) 75Hz (Flicker Free) 300Hz (High Speed)
Power Factor	0.98 (PFC)	0.98 (PFC)
Efficiency	87% (PFC)	87% (PFC)
Dimming Control	55%	55%
Fusing	25A	25A
No-load Voltage	360V	360V
Max. Ambient Temp.	50 °C	50 °C
Class / IP Rating	1 / IP 22	1 / IP 22
Weight	7.4kg	7.4kg

### DIMENSIONS (mm)

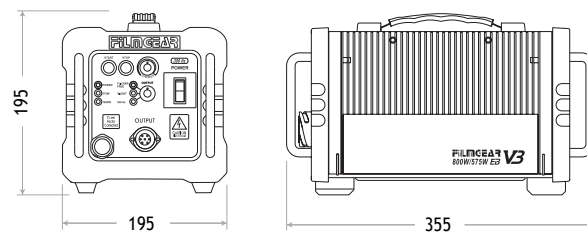

# ELECTRONIC BALLAST V3

## 1.8kW/1.2kW/575W (Multi-Voltage)



### 1.8kW/1.2kW/575W V3 (Multi-Voltage)

SPECIFICATIONS	(1000Hz)	(300Hz)
Identity No.	B518PEK3 (1000Hz, DMX) B518PNK3 (1000Hz)	B518PEX3 (300Hz, DMX) B518PNX3 (300Hz)
Max. Power	1,980VA	1,980VA
Input Voltage	90 - 125V AC 180 - 250V AC	90 - 125V AC 180 - 250V AC
Input Current	11 - 8A @ 180 - 250V AC 22 - 16A @ 90 - 125V AC	11 - 8A @ 180 - 250V AC 22 - 16A @ 90 - 125V AC
Frequency	50Hz or 60Hz	50Hz or 60Hz
Output Mode	60Hz (Silent) 75Hz (Flicker Free) 1000Hz (High Speed)	60Hz (Silent) 75Hz (Flicker Free) 300Hz (High Speed)
Power Factor	0.98 (PFC)	0.98 (PFC)
Efficiency	91% (PFC)	91% (PFC)
Dimming Control	55%	55%
Fusing	25A	25A
No-load Voltage	360V	360V
Max. Ambient Temp.	50 °C	50 °C
Class / IP Rating	1 / IP 22	1 / IP 22
Weight	9.5kg	9.5kg

### DIMENSIONS (mm)

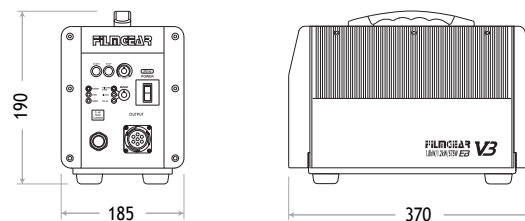

# ELECTRONIC BALLAST V3

## 2500W (Multi-Voltage)



### 2500W V3 (Multi-Voltage)

SPECIFICATIONS	(1000Hz)	(300Hz)
Identity No.	B025PEK3 (1000Hz, DMX) B025PNK3 (1000Hz)	B025PEX3 (300Hz, DMX) B025PNX3 (300Hz)
Max. Power	2,750VA	2,750VA
Input Voltage	90 - 125V AC 180 - 250V AC	90 - 125V AC 180 - 250V AC
Input Current	15 - 11A @ 180 - 250V AC 31 - 22A @ 90 - 125V AC	15 - 11A @ 180 - 250V AC 31 - 22A @ 90 - 125V AC
Frequency	50Hz or 60Hz	50Hz or 60Hz
Output Mode	60Hz (Silent) 75Hz (Flicker Free) 1000Hz (High Speed)	60Hz (Silent) 75Hz (Flicker Free) 300Hz (High Speed)
Power Factor	0.99 (PFC)	0.99 (PFC)
Efficiency	91% (PFC)	91% (PFC)
Dimming Control	55%	55%
Fusing	50A	50A
No-load Voltage	360V	360V
Max. Ambient Temp.	50 °C	50 °C
Class / IP Rating	1 / IP 22	1 / IP 22
Weight	14kg	14kg

### DIMENSIONS (mm)

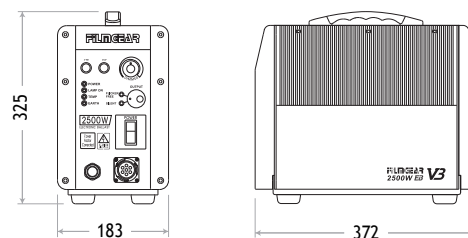

# ELECTRONIC BALLAST V3

## 4kW/2.5kW (Multi-Voltage)



### 4kW/2.5kW V3 (Multi-Voltage)

SPECIFICATIONS	(1000Hz)	(300Hz)
Identity No.	B042PDK3 (1000Hz, DMX) B042PNK3 (1000Hz)	B042PDX3 (300Hz, DMX) B042PNX3 (300Hz)
Max. Power	4,400VA	4,400VA
Input Voltage	90 - 125V AC 180 - 250V AC	90 - 125V AC 180 - 250V AC
Input Current	24 - 18A @ 180 - 250V AC 49 - 35A @ 90 - 125V AC	24 - 18A @ 180 - 250V AC 49 - 35A @ 90 - 125V AC
Frequency	50Hz or 60Hz	50Hz or 60Hz
Output Mode	60Hz (Silent) 75Hz (Flicker Free) 1000Hz (High Speed)	60Hz (Silent) 75Hz (Flicker Free) 300Hz (High Speed)
Power Factor	0.99 (PFC)	0.99 (PFC)
Efficiency	91% (PFC)	91% (PFC)
Dimming Control	55%	55%
Fusing	100A	100A
No-load Voltage	360V	360V
Max. Ambient Temp.	50 °C	50 °C
Class / IP Rating	1 / IP 22	1 / IP 22
Weight	21.7kg	21.7kg

### DIMENSIONS (mm)

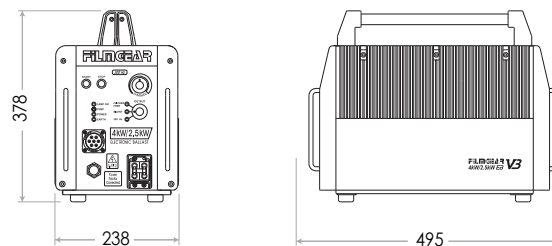

# ELECTRONIC BALLAST V3

## 6000W (300Hz)

6000W V3 (300Hz)

### SPECIFICATIONS

Identity No.	B060PDU3 (300Hz, DMX) B060PNU3 (300Hz)
Max. Power	6,600VA
Input Voltage	180 - 250V AC
Input Current	37 - 26A
Frequency	50Hz or 60Hz
Output Mode	60Hz (Silent) 75Hz (Flicker Free) 300Hz (High Speed)
Power Factor	0.99 (PFC)
Efficiency	91% (PFC)
Dimming Control	55%
Fusing	50A
No-load Voltage	360V
Max. Ambient Temp.	50 °C
Class / IP Rating	1 / IP 22
Weight	27.8kg

\* Bundled with CCL



### DIMENSIONS (mm)

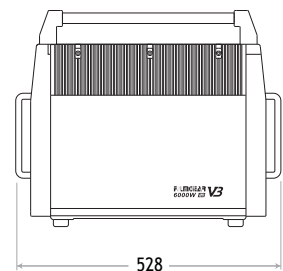
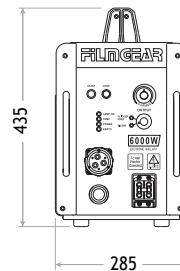

# ELECTRONIC BALLAST V3

## 9kW/6kW (Multi-Voltage, 300Hz)

9kW/6kW V3 (Multi-Voltage, 300Hz)

### SPECIFICATIONS

Identity No.	B096PDU3 (300Hz, DMX) B096PNU3 (300Hz)
Max. Power	9,800VA
Input Voltage	180 - 250V AC
Input Current	54 - 39A
Frequency	50Hz or 60Hz
Output Mode	60Hz (Silent) 75Hz (Flicker Free) 300Hz (High Speed)
Power Factor	0.99 (PFC)
Efficiency	91% (PFC)
Dimming Control	55%
Fusing	100A
No-load Voltage	360V
Max. Ambient Temp.	45 °C
Class / IP Rating	1 / IP 22
Weight	27.8kg

\* Bundled with CCL



### DIMENSIONS (mm)

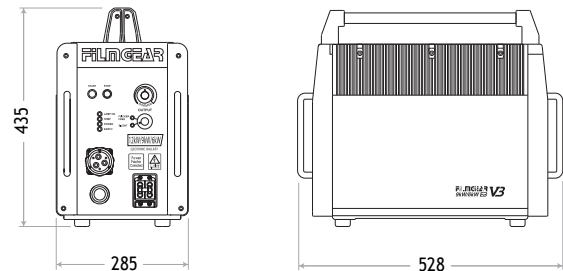



# ELECTRONIC BALLAST V3

## 12kW/6kW (Multi-Voltage, 300Hz)

12kW/6kW V3 (Multi-Voltage, 300Hz)

### SPECIFICATIONS

Identity No.	B126PDY3 (300Hz, DMX) B126PNY3 (300Hz)
Max. Power	13,200VA
Input Voltage	180 - 250V (at 12kW) 90 - 125V (at 6kW) 180-250V (at 6kW)
Input Current	73 - 53A
Frequency	50Hz or 60Hz
Output Mode	60Hz (Silent) 75Hz (Flicker Free) 300Hz (High Speed)
Power Factor	0.99 (PFC)
Efficiency	91% (PFC)
Dimming Control	55%
Fusing	100A
No-load Voltage	360V
Max. Ambient Temp.	45 °C
Class / IP Rating	1 / IP 22
Weight	54kg

\* Bundled with CCL



### DIMENSIONS (mm)

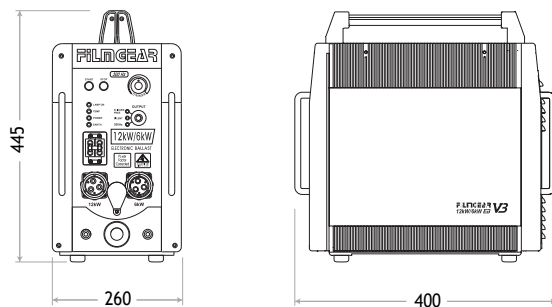

# ELECTRONIC BALLAST V3

## 18kW/12kW (300Hz)

18kW/12kW V3 (300Hz)

### SPECIFICATIONS

Identity No.	B181PDU3 (300Hz, DMX) B181PNU3 (300Hz)
Max. Power	19,300VA
Input Voltage	180 - 250V AC
Input Current	107 - 77A
Frequency	50Hz or 60Hz
Output Mode	60Hz (Silent) 75Hz (Flicker Free) 300Hz (High Speed)
Power Factor	0.99 (PFC)
Efficiency	91% (PFC)
Dimming Control	55%
Fusing	125A
No-load Voltage	360V
Max. Ambient Temp.	45 °C
Class / IP Rating	1 / IP 22
Weight	65kg

\* Bundled with CCL



### DIMENSIONS (mm)

